

# HI-SCAN 6040ds

HEIMANN X-RAY INSPECTION SYSTEM



## Feature Highlights

- **Compact solution for mobile and stationary applications**
- **State of the art technology with HI-MAT<sup>Plus</sup> material classification**

## Optional

- **HI-TIP: Threat Image Projection**
- **Xtrain: Operator training system**
- **IMS: Electronic image storage and archive**
- **Xport: Image export in TIF- or JPEG format incl. automatic transmission to PC via Ethernet**

HI-SCAN 6040ds has been specially developed to prevent the smuggling of dangerous objects in briefcases, handbags, rucksacks, carrier bags etc..

The system stands out with a modern design and a robust structure, optimum dimensions and a very low weight. Therefore, it is excellently suited to be used as a mobile inspection system at changing sites.

The system is filmsafe and able to penetrate up to 30 mm steel. Objects of 60 cm width and 40cm height and unlimited length can be scanned without problems. HI-SCAN 6040ds is very easy to operate.

The scanned objects can be visualized as classified material groups allowing the operator to easily and precisely identify the contents.

The excellent technical equipment facilitates maximum inspection quality at minimum inspection time.

HI-SCAN 6040ds: the robust, light-weight system for security checks in entrance areas

# Technical Data HI-SCAN 6040ds

## General Specifications

Tunnel dimensions	620 (B) x 420 (H) [mm] • 24.4" (B) x 16.5" (H)
Max. object size	615 (B) x 410 (H) [mm] • 24.2" (B) x 16.1" (H)
Conveyor height <sup>1)</sup>	approx. 650 mm (25.6")
Conveyor speed at mains frequency	approx. 0.2 / 0.24 [m/s]
50 Hz / 60 Hz	
Max. conveyor load (evenly distributed)	100 kg (220.5 lbs)
Resolution (wire detectability <sup>3)</sup> )	Standard: 38 AWG (0.1 mm) • typical: 39 AWG (0.09 mm)
Penetration (steel) <sup>3)</sup>	Standard: 27 mm • typical: 30 mm
X-ray dose (typical)	HI-MAT: 1.6 µSv (0.16 mrem)
Film safety	Guaranteed even for high speed films up to ISO 1600 (33 DIN)
Duty cycle	100 %, no warm-up procedure required

## X-ray Generator

Anode voltage • cooling	140 kV cp • hermetically sealed oil bath
Beam direction	diagonal

## Image Generating System

X-ray converter	L-shaped detector line, high resolution
Grey levels stored	4096
Image presentation	B/W, color
Digital video memory	1280 x 1024 / 24 bit
Image evaluation functions	B/W, HIGH, LOW, NEG; incl. Option HI-MAT, additionally VARI-MAT, O <sup>2</sup> , OS electronic zoom: stepless enlargement up to 16-times
Monitor	17" color monitor, low radiation according to MPR II und TCO 99 standards other monitors on request

## Additional Features

Features	Luggage counter, user-id number, display of operating mode, REVIEW-feature to recall previously visible image areas, zoom overview, free programmable keys
Options	HI-TIP, HI-SPOT, SEN, Xport, IMS (Image Management System)

## Installation Data

X-ray leakage	meets all applicable laws and regulations with respect to X-ray emitting devices
CE-labelling	in compliance with 98/37/EWG, 72/23/EWG, 89/336/EWG
Sound pressure level	< 56 dB(A)
Operating- / storage temperature <sup>4)</sup>	0° - 40°C / -20°C - +60°C
Humidity	10% - 90% (non-condensing)
Power supply <sup>5)</sup>	standard: 230 VAC or 110 VAC +10% / -15% • 50 Hz / 60 Hz ± 3 Hz
Power consumption	approx. 0.5 kVA
Protection class system	IP 20
Dimensions • Weight <sup>6)</sup>	1730 (L) <sup>2)</sup> x 797 (B) x 1180 (H) [mm] • approx. 340 kg 68" (L) <sup>2)</sup> x 31.4" (B) x 46.5" (H) • approx. 748 lbs
Mechanical construction	Steel construction with aluminum panels standard color(s): RAL 7016 / stainless steel

<sup>1)</sup> approx. values (adjustable)

<sup>2)</sup> different length of conveyor and mechanical access protection on request

<sup>3)</sup> Conds.: steel step wedge, CU wires, 0.2 m/s belt speed

<sup>4)</sup> extended temperature range on request

<sup>5)</sup> different values optional

<sup>6)</sup> without control desk, keyboard, monitor(s) etc.

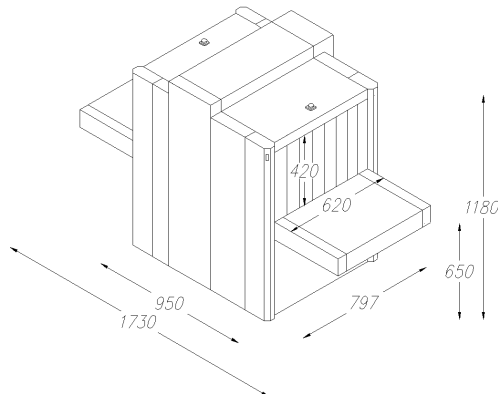

## Germany

Smiths Heimann GmbH  
Im Herzen 4  
65205 Wiesbaden  
T: +49 (0)611 9412-0  
F: +49 (0)611 9412-229  
mail.germany@smiths-heimann.com  
http://www.smiths-heimann.com

## France

Smiths Heimann S.A.S.  
36, rue Charles Heller  
94400 Vitry sur Seine  
T: +33 (0)1 55 53 55 55  
F: +33 (0)1 46 80 34 99  
mail.france@smiths-heimann.com

## UK

Smiths Detection International UK  
459 Park Avenue  
Bushey, Watford  
Herts WD23 2BW  
T: +44 (0) 1923 294400  
F: +44 (0) 1923 294401  
mail.uk@smiths-heimann.com

## USA

Smiths Detection Inc.  
30 Hook Mountain Road  
PO Box 410  
Pine Brook, NJ 07058  
T: +1 973 830-2100  
F: +1 973 830-2200  
mail.usa@smiths-heimann.com

## Canada

Smiths Detection Montréal Inc.  
950 Bergar, Laval (Quebec)  
Canada H7L 5A1  
T: +1 (450) 967-0010  
F: +1 (450) 967-7444  
mail.canada@smiths-heimann.com

## Singapore

Smiths Detection Asia Pacific Pte. Ltd.  
3 Toh Tuck Link #04-01  
German District Centre  
Singapore 596228  
T: +65 6 466-1700  
F: +65 6 469-2506  
mail.singapore@smiths-heimann.com



smiths